

AIRCLAD (X)

X05



+

X015

About AirClad

AirClad X is our brand of event, retail and leisure products with high performance design at its core.

Established in 2007, over the years AirClad X has worked extensively with premium brands and clients to produce one-off, custom designs. As a result of this experience, we have developed our own range of industry-leading products to suit a multitude of applications.

These structures are crafted to engage and inspire people, and to ultimately bring your space to life.

To assist in the installation and delivery of our structures globally, there is a developing network of partners managing deployments from location to location.



Structure: XO 15
Location: Cannes
Client: Twitter



Event Architecture

02

04

07

11

12

14

19

ABOUT THE XO SYSTEM

About XO

AirClad XO system products are premium outdoor coverings, purposefully designed to create bright, open and contemporary spaces.

The system comprises a core frame and cover which can act as a sun shade, or can be partially or fully wrapped to create a sealed, permanent space. The flooring is fully customisable and can be tailored to meet a multitude of needs. Alternatively, the structure can be used without flooring and simply use the ground it sits on.



Structure: XO 15
Location: Cannes
Client: Twitter

ABOUT



XO

15

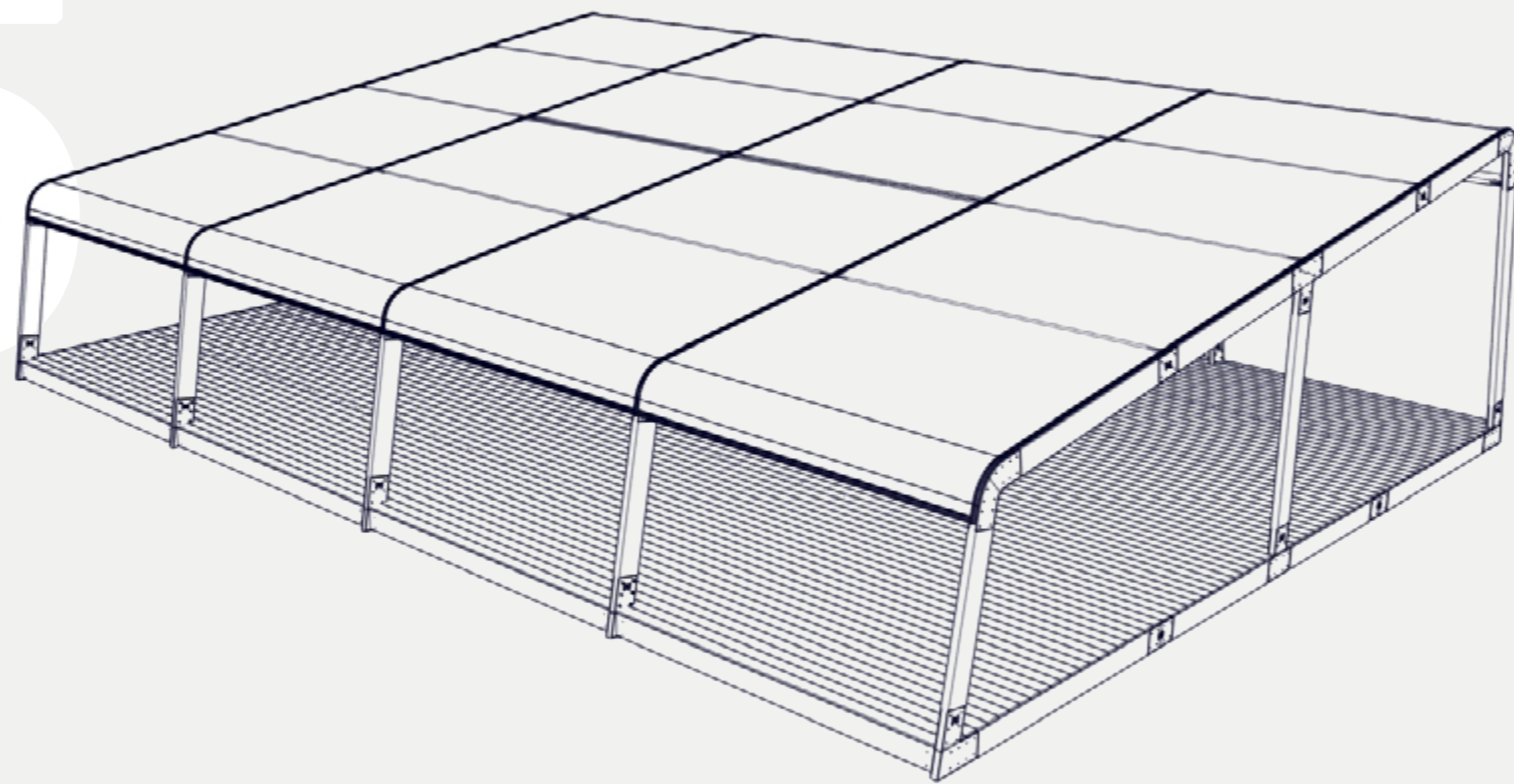

XO

5

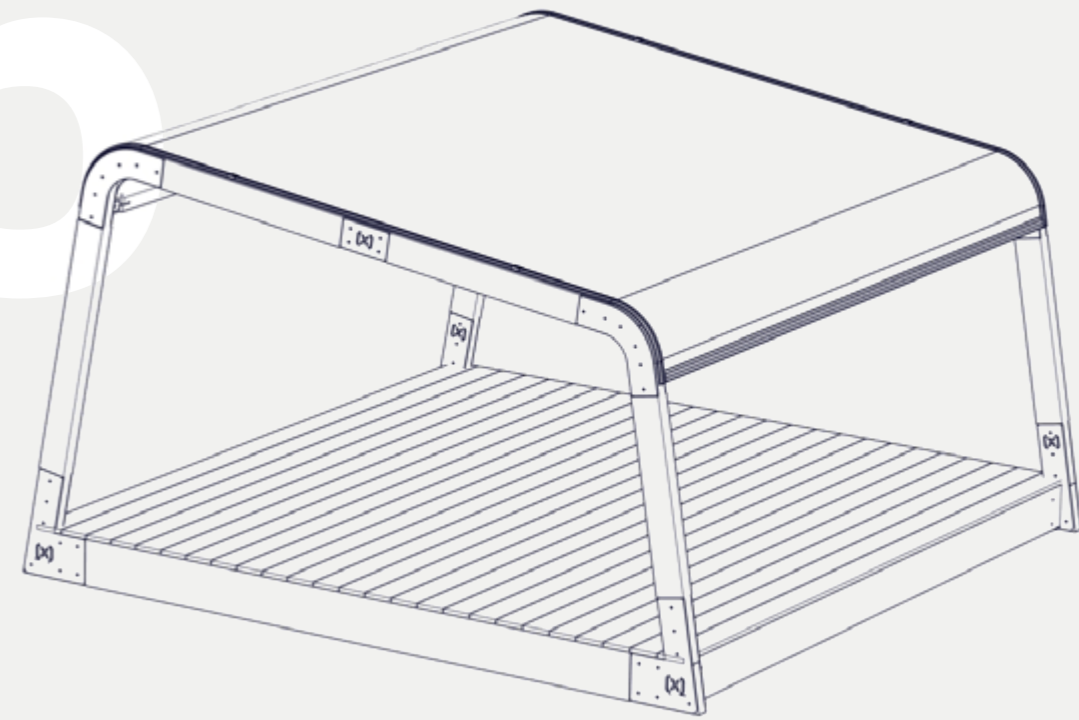

Structure: XO 15

Location: Cannes

Client: Twitter

Enhancements: Timber spaceframe & Solaris Serge Ferrari canopy



ABOUT



XO FOR TWITTER

Twitter Beach

This project was designed and produced to create a VIP beachfront experience in Cannes, France for the Cannes Lions Festival.

Working exclusively with Wonderland Agency, Airclad developed and produced three adjoining XO spaces based on a 5m and 15m grid.

The interior spaces seamlessly integrated with the flow and form of the XO system. Special louvred walls and branded shading was incorporated into the space frame to create an immersive brand experience. The decking was entirely custom, designed and produced for the whole system to link together.

Never has a beach been treated to such contemporary merriment.



Structure: XO 5 + XO 15
Location: Cannes
Client: Twitter

TWITTER



TWITTER



High Performance

All structures are designed for permanent and temporary installations.

Know No Boundaries

The XO is designed and engineered to be used in pretty much any location, on any ground.



FEATURES

Investment Opportunities

No matter what your requirements are, we have a solution to exceed your expectations. We offer various seasonal leasing packages to test and experience AirClad if only needed once, or this can roll into a lease-to-buy option if you want to test before purchasing.



FEATURES



Fabrics

The XO system is designed with a keder track system allowing the use of any fabric. The Ferrari Solaris is used for optimising the sun shading effects in dryer hot conditions, allowing high level of heat reduction while allowing a good air circulation.

For more demanding weather conditions we use a range of polyester PVC twin wall aircells to insulate and add extra strength for wind and other rain loads.

All fabrics have upto 20 years constant life warranty.

Spaceframe

We use Kertu structural engineered plywood laminate for our larger permanent, or long seasonal installations. This is varnished and left with the wood exposed to celebrate the look and feel of the timber.

For pop up events and smaller structures we can use anodise or powder coated aluminium.



Modular

All AirClad systems are based on a fully modular system which allows you to scale up space as needed.

Custom Designs

As a design company at the core we are able to respond to any brief or problem you may need to solve. Our knowledge with design, production as well as our own operations allows us to help you find the right solution for your needs, and if AirClad is not right we will tell you.

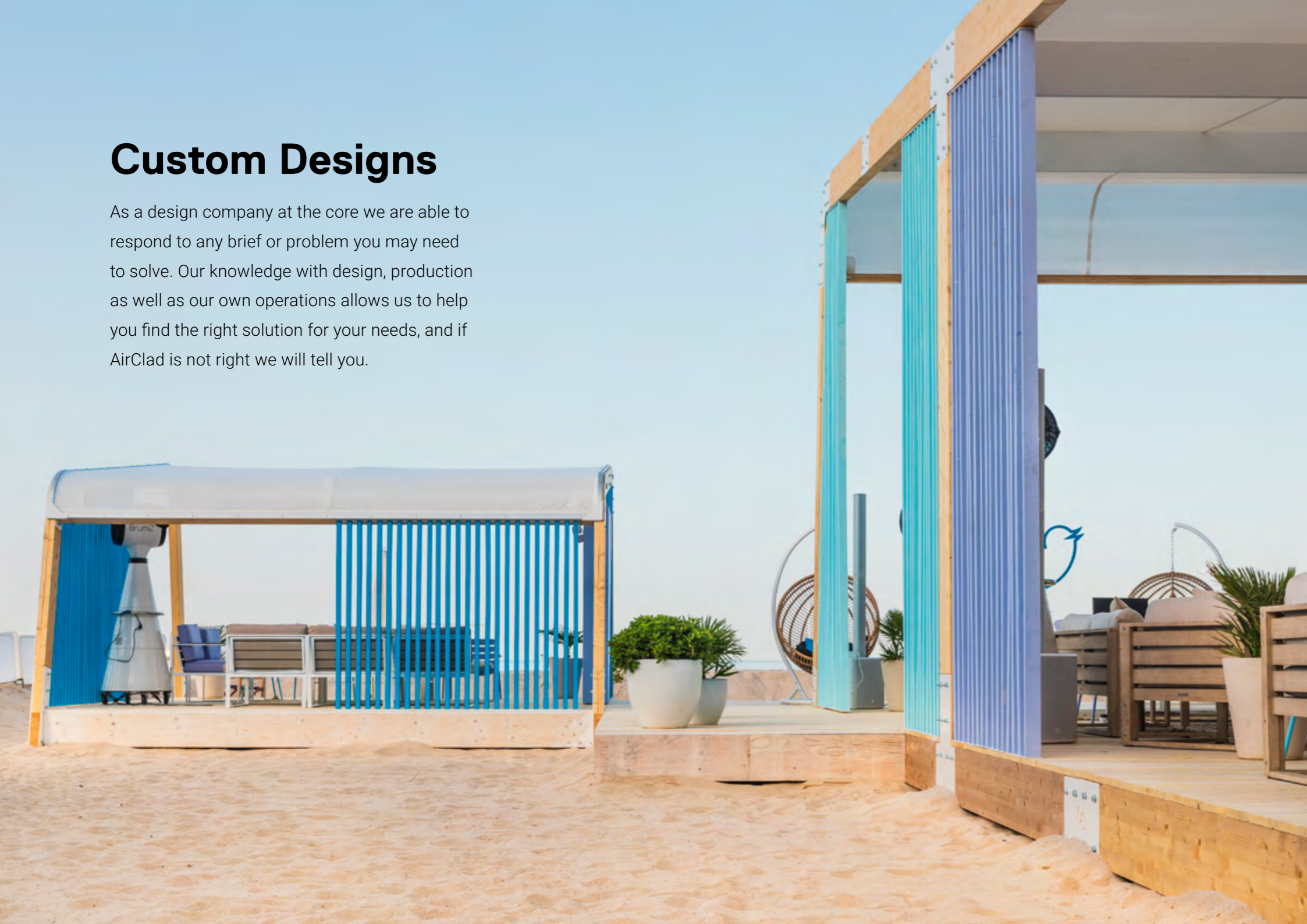

Branding

All our structures are designed to be permanently and temporary branded. Our in house team can assist with templates and full art working as per your requirements.



Making It Personal

All of our core designs have the ability to be fully customised with anything from signage and lighting, to full shopfit and retail spaces.





CASE STUDIES

Broaden the Horizon

**The versatility of the AirClad XO knows
no boundaries.**

The following examples demonstrate some
other opportunities with XO.



Structure: XO 10
Location: Antwerp
Client: Badboot

F1

Launched with the new look F1 the AirClad XO 6 has been a key feature at all races since then. The XO 6 is used in the fanzone as the pit stop challenge. At 20m wide this fully open-facing space is fast and easy to operate while reflecting the strong brand identity of F1.



Sky

The XO 4 is light yet secure. This makes the XO ideal for roof top canopies as shown here being used with the XDEK for Sky at Goodwood festival of speed.



Badboot

This XO10 was the perfect solution to create a transparent bar and restaurant space on this entertainment boat in Antwerp. The system is designed and engineered to be used permanently all year round.





BUY

RENT

LEASE

OUR MISSION

Eco Statement

Our products and systems have been developed with an eco-conscious approach since we started back in 1995.

Sustainability has become an increasingly large part of daily life and as our clients and partners become more aware of the damage that industry is doing to the local and global environment, we are working hard to demonstrate our commitment to sustainable change and searching for solutions together. We believe our business practises reflect a more eco-minded, future-facing approach that is better for all.

AirClad Products are designed for reuse, time and time again. We're proud to say that some of our oldest structures, those that started us on this journey, are still in everyday use over ten years after leaving the factory, with expectations to last way into the future. The modular nature of AirClad enables us to easily replace and refurbish parts, to achieve new aesthetics and minimise breakages. Extending the life of our structures helps us reduce our environmental footprint, yet still we aim to do more.

AIRCLAD (X)

AirClad Ltd
Essenstraat 5
2060
Antwerp
Belgium

info@airclad.com
www.airclad.com

AirClad Ltd
The Echo Building
18 Albert Road
Bournemouth
BH1 1BZ

+44 (0) 1202 942 475



"As a designer, I strive to encourage opportunities of chance, where creativity moves beyond appearance. For me there is joy in developing unique products that challenge convention, inspire and engage."

A white handwritten signature on a dark background, appearing to read 'Nick Crosbie'.

Founder
Nick Crosbie

SPACE FOR LIFE

Design by Inflate
All IP and design rights Te Koop Ltd