

YUMI

(EXPRESS)
SYSTEM

An AirClad X Technical Data Sheet



Updated 23/08/23
by SC

YUMI
TECHNICAL DATA
2.4m by 2.6m

YU MI

(X)

CONTENTS

2.4m by 2.6m

INTRODUCTION	03
CORE PACKAGE	04
COMPARISON CHART	05
ELEVATIONS	06
VISUALS	11

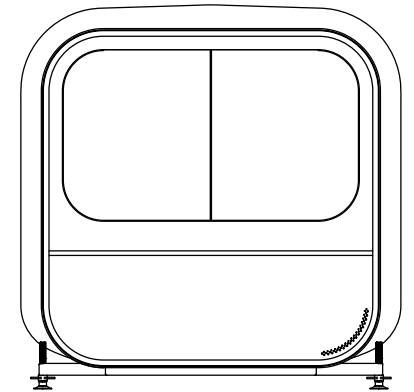

YUMI

INTRODUCTION

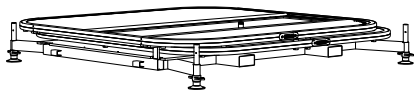
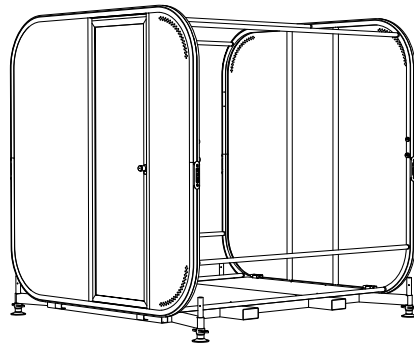
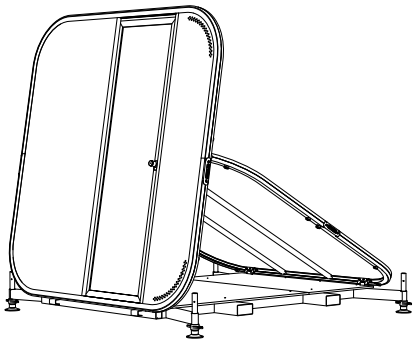
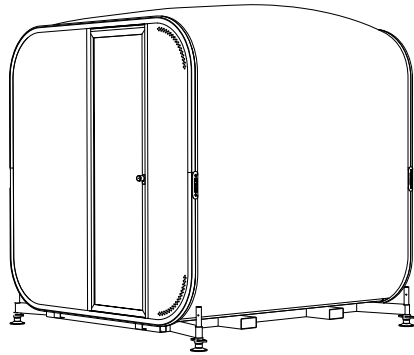

This Technical Data document is designed to assist prospective clients and operators by offering a scope of the physical aspects of this AirClad X structure. The information provided is intended as a guide and should not be used to overlay detailed plans. 3D CAD files are available for project-specific applications on request.

Initially designed to compliment the SNOOZY sleeping pods as a check-in reception, Yumi has now found its own fan base in the service industry. This go-anywhere, pop-up kiosk turns heads wherever it's used. The YUMI is easily branded to take on any identity and looks great while serving you.

The YUMI is the perfect pop-up kiosk or serving station for any event. It's simple, stylish front fascia and clean lines give a distinctive, graphic look - complementing any brand, product or service.

It features a 1.5m wide serving hatch that creates an integrated awning when open. Easily deployable on any terrain, YUMI has height adjustable galvanised feet for fast levelling. This product is specially designed for the events & catering industry and serves up unparalleled style, portability and ease of use.

The Yumi is proudly designed and produced in the EU and is engineered to Euro Code 13782.

NOTE

For the purposes of the data sheets, the information provided is based on single double sliding doors to the front with a closed fascia to the rear. For information on operations and health and safety please refer to product logbook.



YUMI

CORE PACKAGE

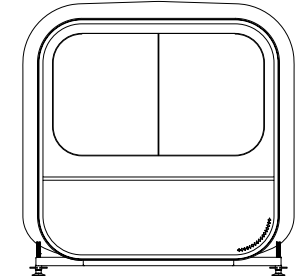

Structural Frames:	2
Cross bracing:	9
Flooring:	1 large board 1 small board
Fascia:	2 serving hatch doors 1 upper front surround 1 lower front panel 1 rear fascia with door
AirCells:	1
Air management systems:	1
Connection Hoses:	1

PACKED STRUCTURE DETAILS

Max Packed Size:	1x 2.7 m by 2.5 m by 0.6 m
Packed weight:	744 kg

BUILT STRUCTURE DETAILS

Max External footprint:	2.5 m by 2.6 m (6.25 m ²)
Internal usable area:	1.7 m by 2.3 m (3.9 m ²)
Max height:	2.7 m
Frame Cross section:	56 mm by 52 mm
Cross bracing cross section:	35mm Diameter
Structure total weight:	744 kg
Transport:	1x artic lorry
Capacity:	3 people

MATERIALS

AirCells:	FR treated, polyester-reinforced PVC
Frame:	Anodised aluminium extrusion
Cross bracing:	Anodised aluminium extrusion
Sub-floor:	Galvanized box section steel
Flooring:	18mm resin-coated plywood
Glazing:	8mm HPL / Polycarbonate

POWER

Air Management system: draws 1.4amp

INSTALLATION AND DERIG GUIDE

Crew:	min. 3 people
Crew Leader:	1 person
Set up time:	from 25 minutes
Derig time:	from 25 minutes
Tools required:	General toolkit & step ladder

NOTE

This page refers to setting up a structure, fixing and pressurising of AirCells only. The subsequent guidance represents the minimum required action to achieve a safe and secure installation. Timings indicated may vary due to on-site conditions, access, weather and other elements outside of our control. We always recommend pre-installation site visits where possible in advance of any goods arriving on site. AirClad accepts no responsibility for damages to equipment, injuries to persons, or loss of earnings due to structure installation undertaken by third-party operators.



YUMI

ELEVATIONS

All sizes in mm.

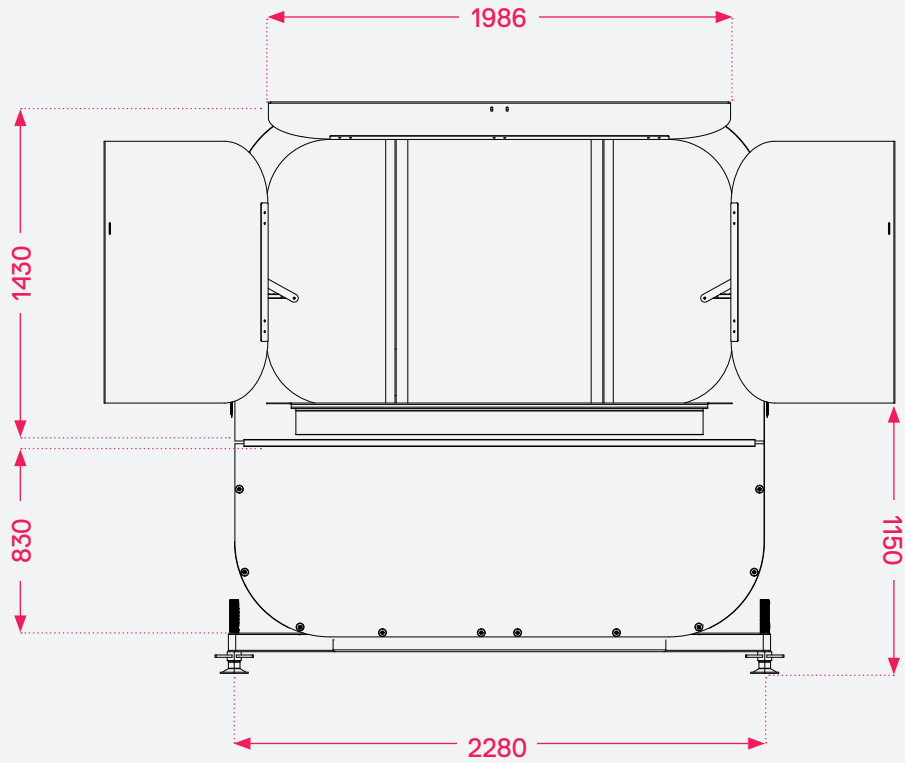

FRONT ELEVATION

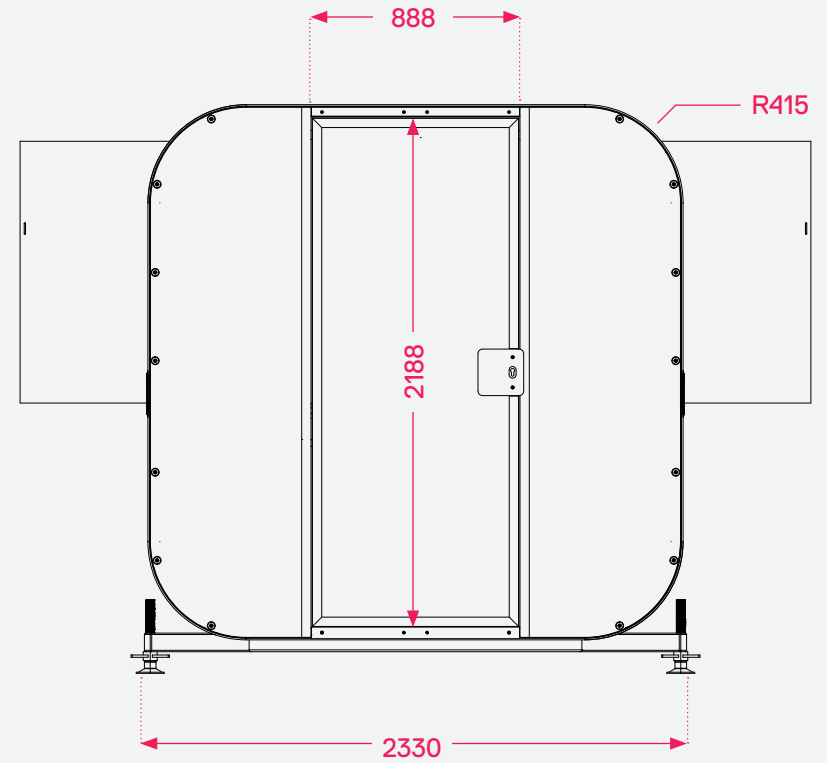

REAR ELEVATION



YUMI

ELEVATIONS

All sizes in mm.

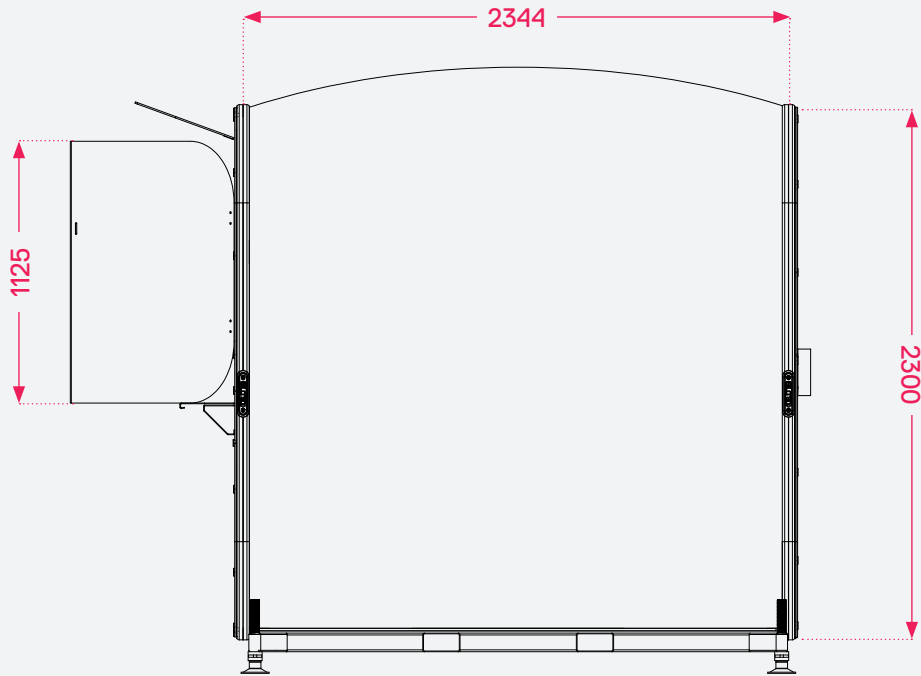

SIDE ELEVATION

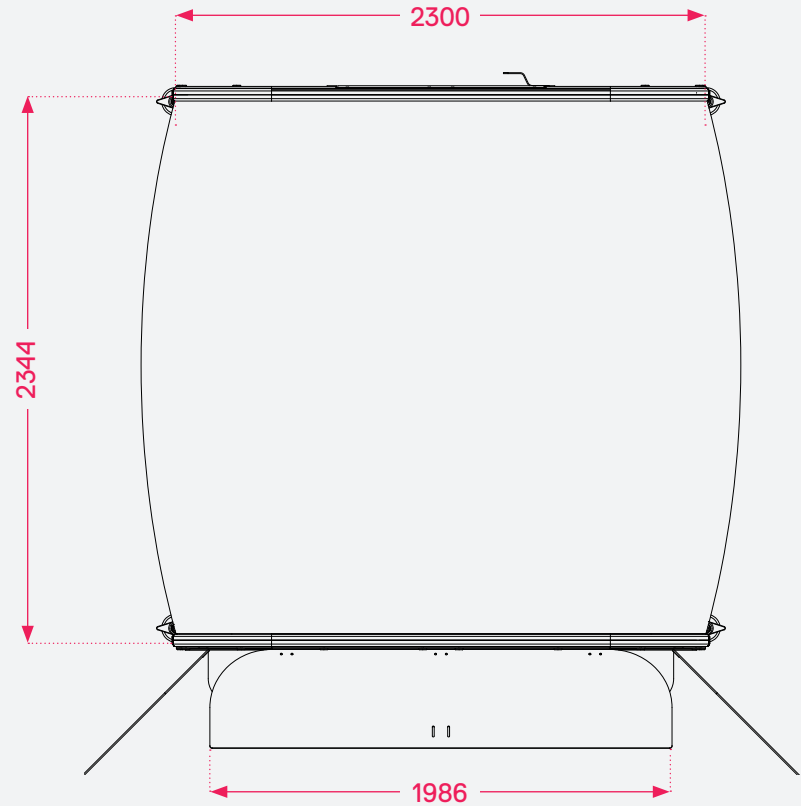

PLAN



YUMI

DAISY CHAIN

You can daisy chain up to 120 units with one fan system.

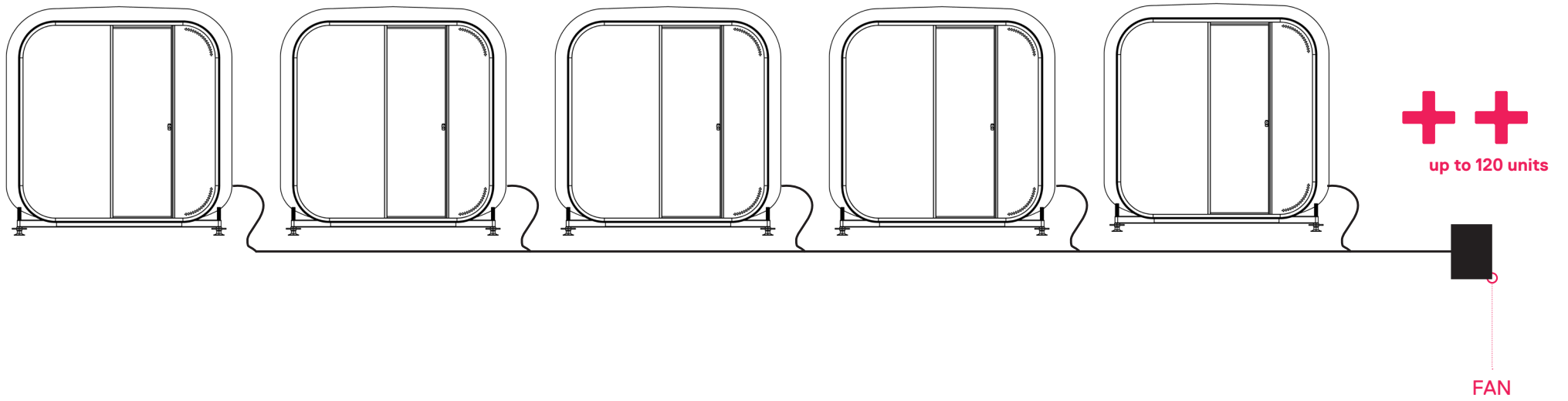

YUMI

ELEVATIONS

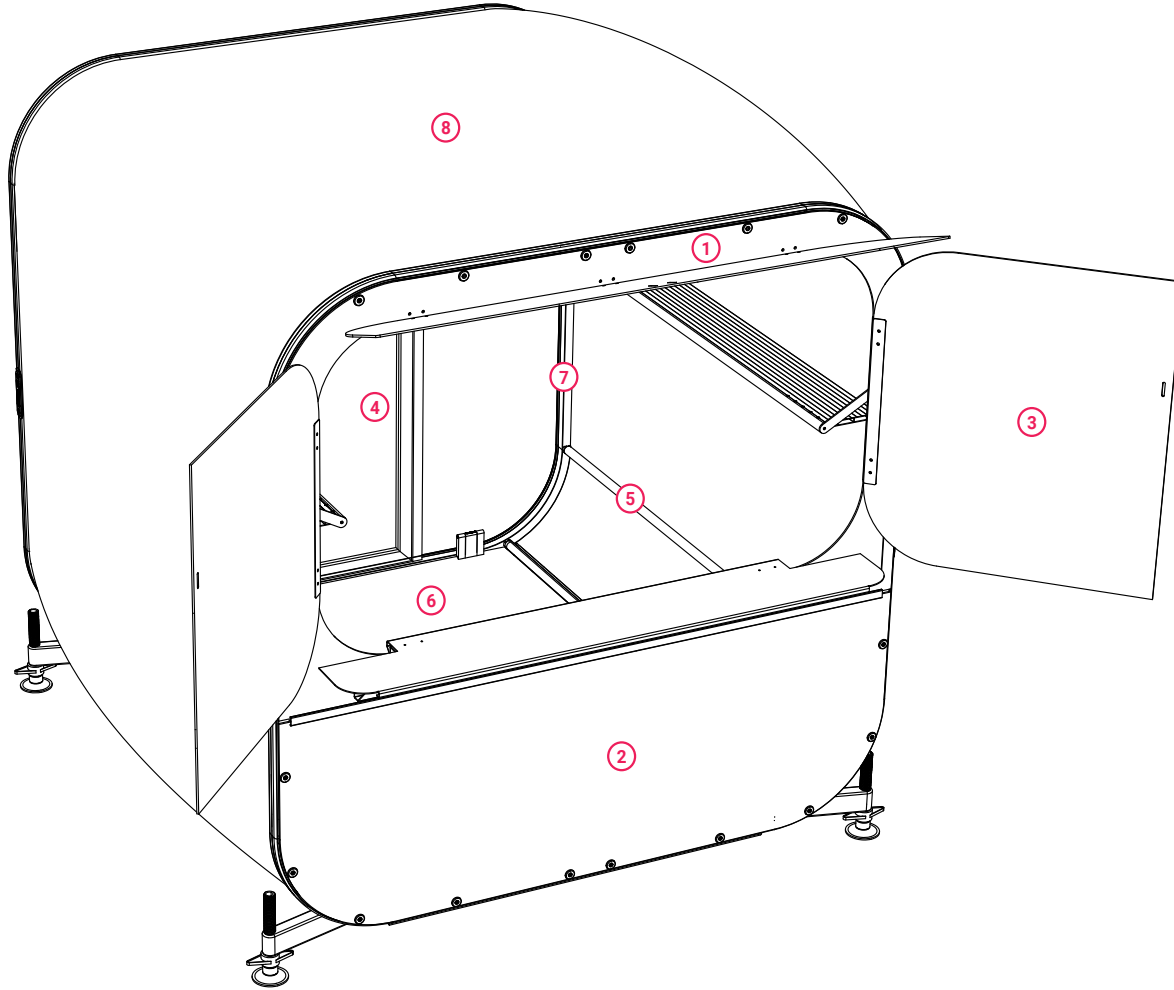

Item No.	Description	QTY.
①	Upper Front Surround Fascia	1
②	Lower Front Fascia Panel	1
③	Fascia Serving Hatch Doors	2
④	Rear Fascia with Door	1
⑤	Cross Brace Single	9
⑥	EXPRESS Floor	2
⑦	SpaceFrames	2
⑧	EXPRESS AirCell	1



METROPOLITAN RAILWAY

FARRINGDON & HIGH HOLBORN

FARRINGDON STATION

Circle line
Hammersmith & City line
Metropolitan line

FARRINGDON STATION

Organic Coffee

★ PETIT PRET

ENTRANCE

clerkenwell 23-25
design week may

tickets and information

sponsored by

RAK
CERAMICS





AIRCLAD (X)

AirClad Ltd
The Echo Building
18 Albert Road
Bournemouth
BH1 1BZ

info@airclad.com
www.airclad.com

AirClad Ltd
Amerikalei 91
2000 Antwerpen
Antwerp
Belgium

+44 (0) 1202 942 475

SPACE FOR LIFE

Design by Inflate
All IP and design rights Te Koop Ltd